

Estimation the nonlinear impairment of single channel transmission systems with arbitrary parameters

Xiaosheng Xiao, Shiming Gao, Yu Tian, and Changxi Yang

State Key Laboratory of Precision Measurement Technology and Instruments, Tsinghua University, Beijing 100084, China

ABSTRACT

A database is founded to estimate the nonlinear impairments of single channel return-to-zero (RZ) transmission systems with arbitrary parameters. Our link setup consists of multi-span transmission fiber and dispersion compensation component, with dispersion slope full compensating. The total transmission distance and the transmission fiber could be arbitrary, i.e. with arbitrary nonlinear coefficient, attenuation and dispersion. The parameters of input signal could also be arbitrary, i.e. with arbitrary transmission rate, input power, and any duty cycle of RZ pulse. Even the amplification schemes could be single-stage erbium-doped fiber amplifier (EDFA), or double-stage EDFA, or hybrid EDFA-Raman amplification. The database is obtained by numerous numerical simulations, neglecting the amplified spontaneous emission noise, polarization mode dispersion. The performance of transmission system impaired by nonlinear effects is represented by eye opening penalty (EOP). One can use the database to estimate the EOP of single channel transmission systems with bit rate up to 160 Gb/s, and can also evaluate the maximum transmission distance for given system impairment conveniently. For high-bit-rate transmission systems, intra-channel nonlinearity dominates the nonlinear impairments, therefore, the database to asses the nonlinear impairment of single channel transmission link is also valid for high-bit-rate wavelength-division multiplexed (WDM) systems. The accuracy and the limitation of the database are also discussed.

Keywords: Fiber transmission, performance estimation, nonlinear impairment, self-phase modulation (SPM), intrachannel nonlinearity.

1. INTRODUCTION

Nonlinear impairment is one of the limitations of optical fiber communication. In order to obtain high optical signal-to-noise ratio (OSNR) and overcome the amplified spontaneous emission (ASE) noise, the input signal power should be high enough. With the increasing of transmission data rate, transmission distance, and the length of amplifier span, the signal power is more and more high. However, decreasing the nonlinear coefficient of transmission fiber is very difficult. Therefore, the performance of transmission system is impaired more and more by the nonlinear effect.

When designing a transmission system, the nonlinear impairment is usually investigated by solving the nonlinear Schrödinger equation with split-step-Fourier method¹. Several simulation tools are commercially available now and the simulation results is very precision. However, this approach is time consuming, especially for long haul transmission systems and high optical power input. Thus it is only suited for the selected system configurations and is difficult to start a new system design. In order to reduce the system design time and provide a convenient engineering rule, a lot of simplified models have already been proposed^{2,3}, which are obtained by heuristic approach and can be used to estimate the impact of nonlinear effects on the performance of systems or to determine the maximum nonlinearities-limited transmission distance easily. However, the heuristic constants (e. g. P_{\max} in Ref. 2 and $\Phi_{\text{NL,Limit}}$ in Ref. 3) obtained in the literature to represent the maximum permission of nonlinear impairment are only valid for a specific system configurations, and for links with different fiber type or data rate the constants changes and should be calibrated through numerical simulations. Even for a given system configuration, the heuristic constants are not known and one has to calculate it by numerical method. Moreover, the transmission system types considered in the literature are limited by the kind of nonlinear effects. Ref. 2 aims to the SPM-limited transmission system, the data rate of which is not very high and the pulse width is not very short. Whereas, Ref. 3 investigates the intrachannel nonlinearities-limited system with 160 Gb/s data rate. A more fast and convenient design rule is needed.

A database for first-order performance estimating is founded in this paper, which is suit for single channel return-to-zero (RZ) transmission systems with arbitrary parameters. The database is valid for optical fiber systems with arbitrary total transmission distance and transmission fiber style, i.e. the nonlinear coefficient, attenuation and dispersion

of transmission fiber could be arbitrary. Also the signal could be transmitted with arbitrary transmission rate, input power, and any duty cycle of RZ pulse. Moreover, the amplification schemes could be single-stage erbium-doped fiber amplifier (EDFA), or double-stage EDFA, or hybrid EDFA-Raman amplification. Since intrachannel nonlinearity is the dominant nonlinear impairments in high-bit-rate wavelength-division multiplexed (WDM) systems, the database to predict the nonlinear impairment of single channel systems is also valid for high-bit-rate WDM systems. Using the database, one can predict the nonlinear impairment of transmission systems with data rate up to 160 Gb/s and assess the maximum transmission distance without numerical simulations.

The remainder of this paper is organized as follows. Transmission system considered in this paper is presented in Section 2. The founding of the database and an approximate theoretical model for nonlinear impairment estimating is shown in Section 3. In Section 4, the accuracy and the limitation of the database are discussed. Section 5 gives the conclusion.

2. SYSTEM SETUP

In order to concentrate on the impact of nonlinear distortions on the system performance, the ASE noise and polarization-mode dispersion are neglected. Fig. 1 presents the basic system setup used in this paper, which consists of an ideal electrical transmitter (Tx), N spans cascaded transmission fibers followed by full dispersion and dispersion slope compensation modules (DSCMs), noiseless optical amplifiers to full compensate the loss of transmission span, and a receiver (Rx) which includes a pre-amplifier, an optical filter, a square law detector and an electrical filter. The DSCMs could be dispersion compensating fibers (DCFs) or fiber grating, the latter DSCMs is linear and the nonlinear effect of it can be neglected.

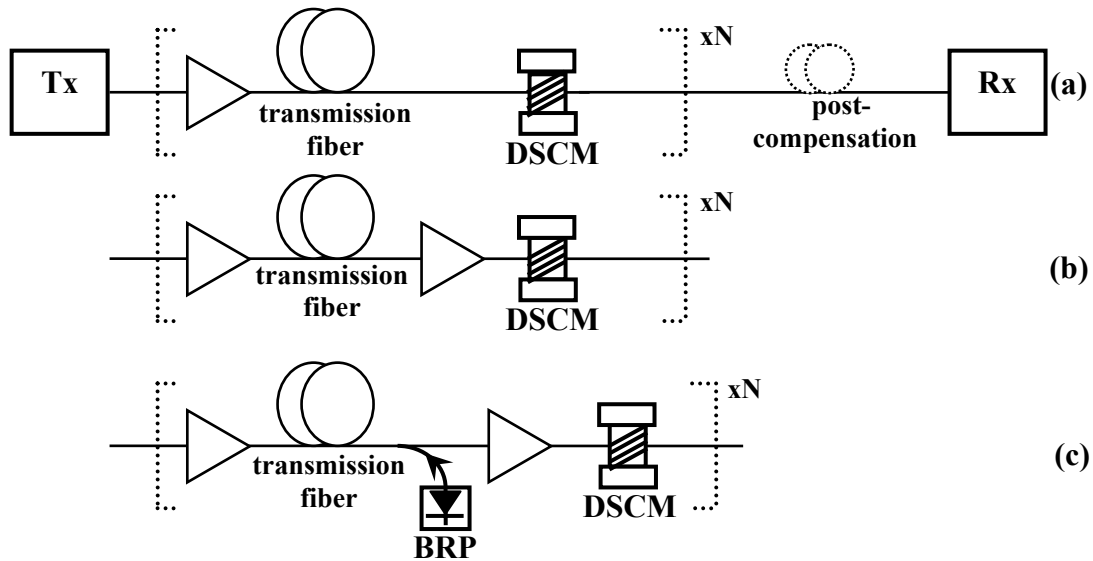

Figure 1. System configurations considered with different amplification schemes. The amplification schemes are (a) Single-stage EDFA, (b) double-stage EDFA, and (c) hybrid EDFA-Raman amplification. EDFA: erbium-doped fiber amplifier, BRP: backward Raman pump.

Three amplification schemes are considered: a single-stage EDFA is used to compensate the loss of each span including transmission fiber and DSCM [Fig. 1(a)], a double-stage amplifier with a second EDFA in front of the DSCM [Fig. 1(b)], and a hybrid EDFA-Raman amplification scheme including a double-stage EDFA and an additional backward Raman pump placing at the end of the transmission fiber [Fig. 1(c)]. In this paper, the systems with and without optimal postcompensation [see Fig. 1(a)] are both considered.

The signal quality is represented by eye opening penalty (EOP) which is calculated by

$$\text{EOP} = 10 \log_{10} \frac{\text{EO}_{b2b}}{\text{EO}_{tr}} \quad (1)$$

where EO_{b2b} and EO_{tr} are the back to back eye opening and the eye opening after transmitting the whole link, respectively, and the eye opening is evaluated at the receiver output putting a rectangular mask inside the eye pattern with a width of 0.2 times the bit rate.

3. DATABASE

To consider the degradation of the system's performance caused by nonlinearities, a criterion called cumulative nonlinear phase shift (NPS) has been developed to measure the nonlinear effect of the transmission systems^{3,4}. The shortcoming of this criterion is that comparing NPS is only valid for systems with given transmission fiber and bit rate, thus for systems with different transmission fiber or bit rate, NPS has to be calibrated through numerical simulations. On the other hand, the nonlinear impairments for links with different bit rates and transmission fibers are compared in Ref. 5 and it is found that the result of signal degradation due to nonlinearities only depend on the product DB^2 , where dispersion parameter D bit rate B , provided the other parameters, such as input power, nonlinear coefficient of transmission fiber, etc., are constants. From the analyses above, a conclusion can be deduced that, for a system, the nonlinear impairment represented by EOP is determined by two parameters only, NPS and the product DB^2 . Moreover, in Ref. 3 it is verified EOP is approximate proportional to NPS if the parameters D and B are given, where $B=160$ Gb/s and the intrachannel nonlinearities dominant the nonlinear impairments. We extend this result to the systems with other bit rates that EOP is approximate proportional to NPS if given DB^2 , and found a database which is composed by a series EOP for different DB^2 and constant NPS, to fast estimate the nonlinear impairment for different system configurations.

All the data in the database are obtained by solving the nonlinear Schrödinger equation with split-step-Fourier method¹ and is based on the system setup of Fig. 1(a). In the simulations for obtaining the data of the database, a deBruijn bit sequence (DBBS)⁶ of 512 bits is used, i.e., adding a "0" bit to a pseudorandom binary sequence at a place where there are the longest run of zeros. The DBBS with period 2^m is one that has all possible patterns of m bits and represents the average distribution of bit patterns of length up to m bits. The RZ signal is represented by chirp-free Gaussian pulse with pulsedwidth equal to 50% of the bit duration. The optical filter of receiver is simulated by a 2nd super Gaussian filter with bandwidth of two times the data rate, and the electrical filter is represented by a Bessel filter with bandwidth of 70% of the data rate. The simulation parameters are: span number $N=1$, average input power is $P_0=12$ dBm, the duty cycle of RZ pulse is $d=0.5$, the length of transmission fiber is $L=80$ km, the attenuate of transmission fiber is $\alpha=0.2$ dB/km, the nonlinear coefficient of transmission fiber is $\gamma=1.317$ W⁻¹km⁻¹, the dispersion slope is $D_3=0.056$ ps/km/nm². The data are shown in Fig. 2 and one can estimate EOP for systems with arbitrary parameters through it according to the approach described as follows.

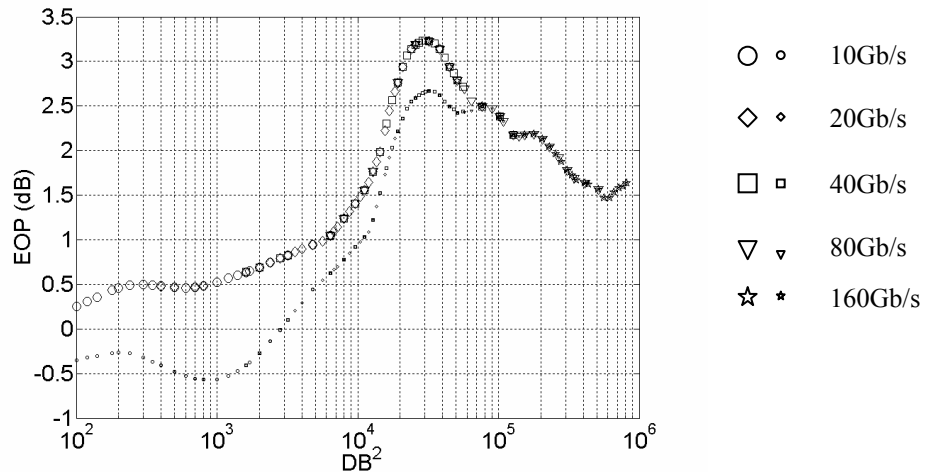

Figure 2. EOP for systems without (bigger marker) and with (smaller marker) optimal postcompensation versus system parameter DB^2 . All the values of NPS are constant.

When the signal transmits at rate above 10 Gb/s, and input signal is Gaussian-shaped pulses with not very high power, and if all the dispersion of the transmission link is compensated for, the amplitude of the output field can be presented as $A(L,t)=A(0,t)+A_p(L,t)$, where $A(0,t)$ is the injected signal, and A_p is the perturbations caused by intra-channel

nonlinearities whose analytical expression can be obtained through perturbation theory⁷. Assuming no phase coding, the maximum distortion caused by single pulse SPM or intrachannel nonlinearities generated after transmission over the transmission link with full dispersion compensation can be described as follows:

$$A_p(L, t) = A_0^3 \int_0^L dz i \gamma(z) f(z) g(z, \beta_2 / \tau^2), \quad (2)$$

where A_0 is the peak amplitude of the field of input pulse, γ is the nonlinear coefficient, $f(z)$ is the power profile of the link normalized to the input power A_0^2 ; $g(z, \beta_2 / \tau^2)$ is a function representing the dispersion map and only depends on β_2 / τ^2 , β_2 is the group-velocity dispersion parameter of transmission fiber and τ is the half-width at 1/e-intensity point of the input RZ pulse. Since β_2 is proportional to D , and for transmission system with given bit rate and pulse shape, τ is proportional to the reciprocal value of B , the results only varies with the product DB^2 . Furthermore, if γ is constant along the transmission fiber and the DCF, an approximate relation between A_p and A_0 can be obtained:

$$A_p / A_0 \propto P_0 \int_0^L dz f(z) \gamma(z) = \sum_{all\ span} (\gamma_1 P_0 L_{eff1} + \gamma_2 P_2 L_{eff2}), \quad (3)$$

where γ_1, P_0, L_{eff1} are the coefficient, input power, and effective length of transmission fiber, respectively, and γ_2, P_2, L_{eff2} are the coefficient, input power, and effective length of DCF, respectively. The summation in Eq. (3) is just the NPS³ represented by Φ_{NL} . Then we get

$$A_p / A_0 = C \Phi_{NL}, \quad (4)$$

where C is a constant and depends on the system parameter DB^2 .

Assuming $A_p / A_0 \ll 1$ and using Eq. (4), the EOP of Eq. (1) can be rewritten as follows:

$$EOP \propto \log_{10} \frac{|A_0|^2}{|A_0 - A_p|^2} = C_f \log_{10} (1 - C \Phi_{NL}), \quad (5)$$

where C_f is another constant represents the character of receiver, and it depends on the optical filter and electrical filter of the receiver. From numerous simulations, it is found C_f is about -6.5 for the consider system (the limitation of C_f is discussed in Section 4). Then using the data in Fig. 2, substituting the value of Φ_{NL} and the relative EOP, the other constant C can be obtained for systems with different DB^2 .

The correlations between NPS and EOP for different bit rate and dispersion parameter are show in Fig. 3. In order to get a more accurate value of C , one can use more data to calculate C as shown in Fig. 4. The values of C for general transmission rates and fibers are shown in Table 1 and 2.

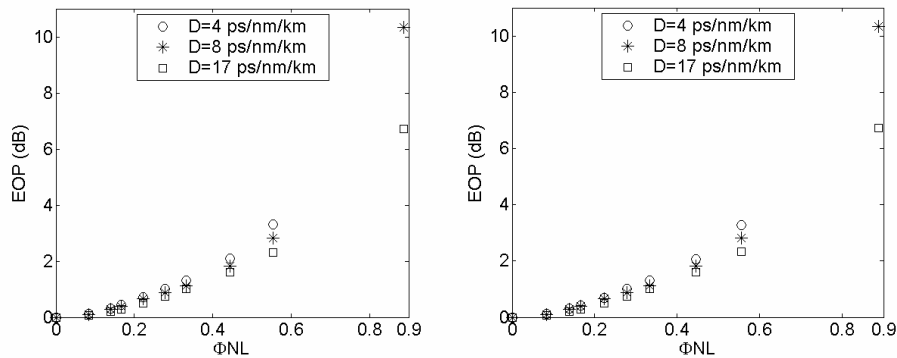

(a) 160 Gb/s

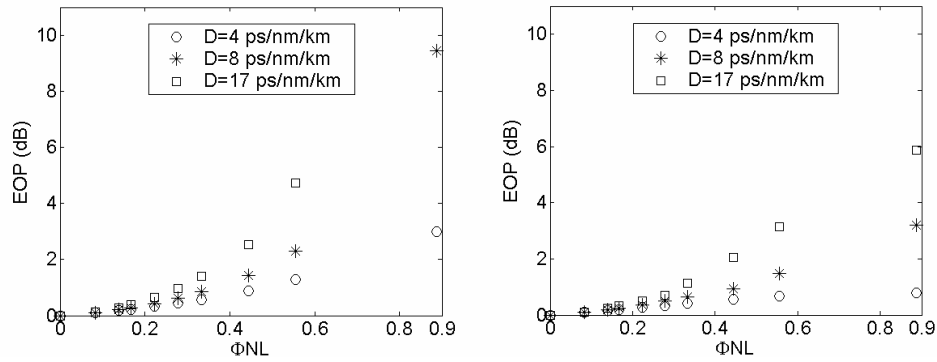

(b) 40 Gb/s

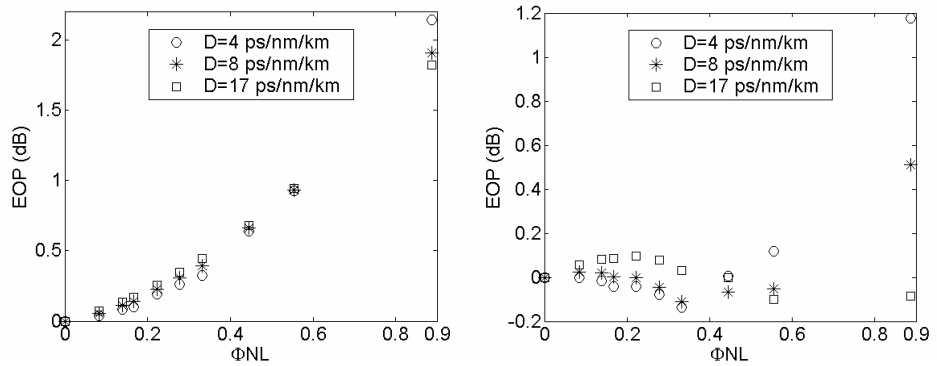

(c) 10 Gb/s

Figure 3. EOP for systems without (left column) and with (right column) optimal postcompensation versus system parameter NPS.

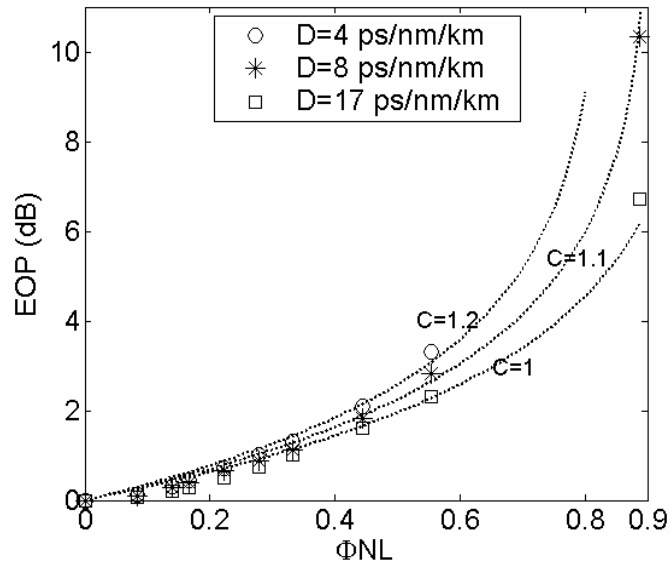

Figure 4. Calculation of constant C . The data is from the left figure of Fig. 3(a).

Table 1. The value of constant C in Eq. (5) to calculate the EOP for systems with different DB^2 and without postcompensation.

Dispersion (ps/nm/km) \ Bit rate (Gb/s)	4	8	17
10	0.65	0.65	0.65
40	0.7	1.1	1.3
160	1.2	1.1	1.0

Table 2. The value of constant C in Eq. (5) to calculate the EOP for systems with different DB^2 and with optimal postcompensation.

Dispersion (ps/nm·km) \ Bit rate (Gb/s)	4	8	17
10	(None)		
40	0.4	0.7	1.1
160	1.2	1.1	1.0

The correlation between EOP and NPS for systems with different amplification schemes [see Figs. 1(b) and (c)] are shown in Fig. 5. From Fig. 5 it can be seen that the database is valid for different amplification schemes.

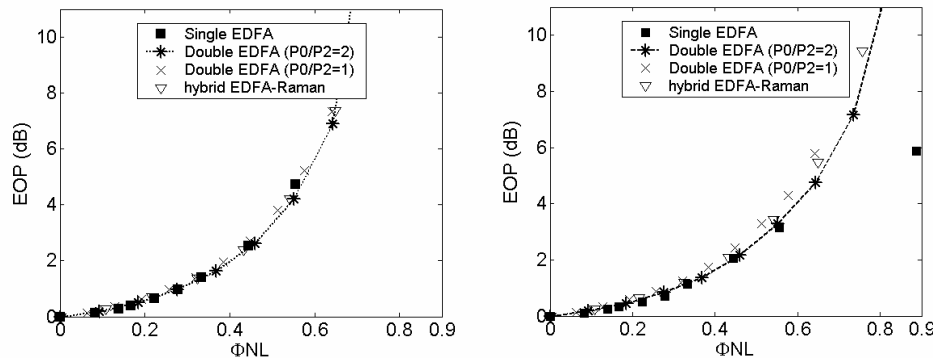

Figure 5. For systems with different amplification schemes, EOP for systems without (left) and with (right) optimal postcompensation versus system parameter NPS.

It has been demonstrated by numerical simulations that, for the systems whose signals are modulated to NRZ and RZ format with different duty cycles d , the nonlinear impairments (represented by EOP) are proportional to d , provided the pulse edge geometry remains constant⁸. Then for systems with different duty cycles, the database is also valid by multiplying the ratios of duty cycle.

For given maximum EOP, EOP_m , one can obtain the maximum span number, thus total distance, with $N_m = EOP_m / EOP_{per}$, where EOP_{per} is the nonlinear impairment of one span.

4. DISCUSSION

To investigate the accuracy and limitation of the database, we test it for system with $B=40$ Gb/s and $D=8$ ps/km/nm. For random bit sequences, the errors of EOP without and with optimal postcompensation of is $<5\%$ and $<3\%$, respectively. For bit length of 2^{11} , the values of that are bigger 5.4% and 4.4% than that of bit length 2^8 . With the same bit sequence, dispersion slope D_3 varies from 0.015 to 0.009 ps/km/nm², the errors of EOPs are $<5\%$ and $<2\%$. For different receivers with bandwidth of optical filter no less than 1.25 and no more than 3 times bit rate, and electrical filter no less than 0.7 and no more than one times bit rate, the errors of EOPs is about 10%.

The effect of attenuate of transmission fiber is shown in Fig. 6. Then for fibers with α no less than 0.2, the errors of EOP is less than 20%.

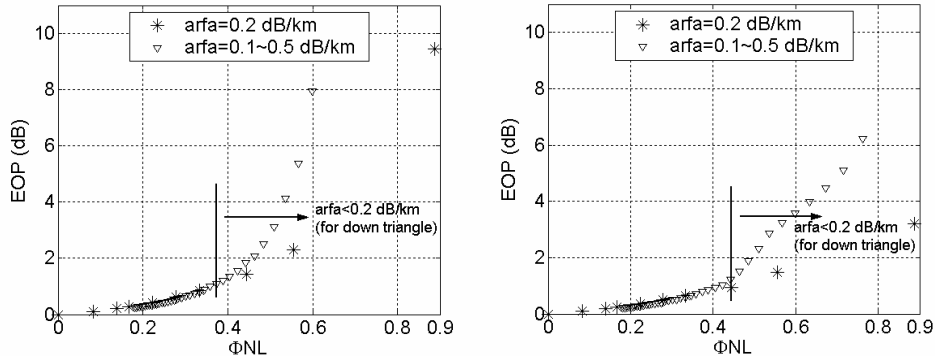

Figure 6. For transmission fiber with different attenuation, EOP for systems without (left) and with (right) optimal postcompensation versus system parameter NPS.

Due to the fiber loss, the signal power decreases along the transmission fiber, and the nonlinear penalty is mainly resulted from the nonlinear interaction occurring in the first part of a long fiber. Thus the effective length L_{eff} is introduced to represent the equivalent distance nonlinearities happening. Supposing a transmission fiber with nominal length L and loss α , $L_{eff} = [1 - \exp(-\alpha L)]/\alpha$. L_{eff} approaches its asymptotic value $1/\alpha$ when $L > 2/\alpha$ and for typical single mode fiber $1/\alpha \approx 22$ km. For general transmission systems the span length L is longer than 50 km, so the effective length, and thus the nonlinear penalty, keeps constant when increasing the span length.

For future investigation, the database can be extended to system with optimal dispersion mapping, i.e. with optimal precompensation, inline compensation, and postcompensation, as shown in Fig. 7. The EOP data and the correlation between EOP and NPS are shown in Figs. 8 and 9.

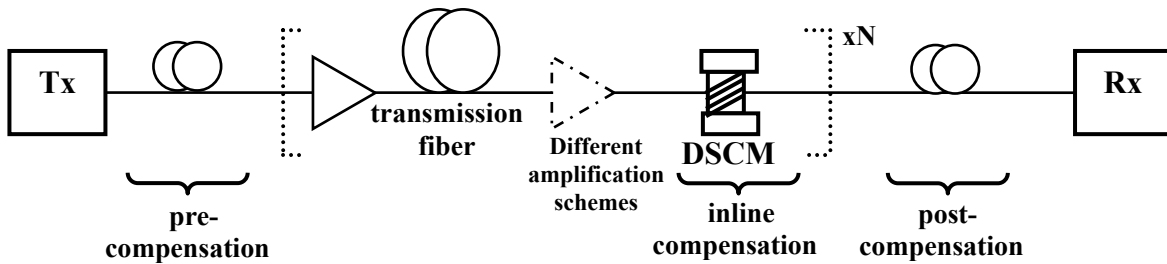

Figure 7. System configurations considering optimal dispersion mapping.

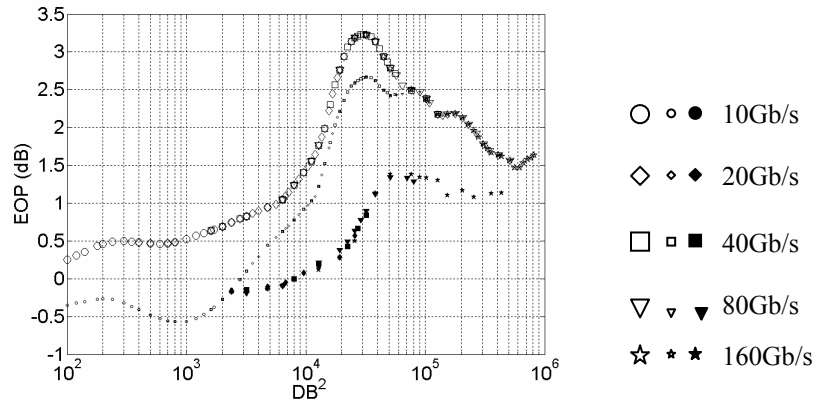

Figure 8. EOP for systems with optimal dispersion mapping (middle marker) versus system parameter DB^2 . All the values of NPS are constant.

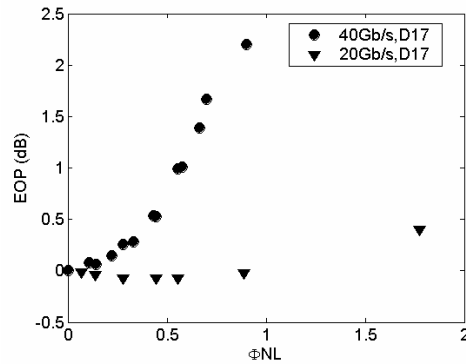

Figure 9. Minimum EOP versus system parameter NPS.

5. CONCLUSION

A database is founded to estimate the nonlinear impairments of single channel return-to-zero (RZ) transmission systems with arbitrary total transmission distance, arbitrary nonlinear coefficient, attenuation and dispersion for transmission fiber, and arbitrary transmission rate, input power, duty cycle of RZ pulse. Moreover, the amplification schemes could be single-stage EDFA, or double-stage EDFA, or hybrid EDFA-Raman amplification. One can use the database to estimate the EOP of single channel transmission systems with bit rate up to 160 Gb/s, and can also evaluate the maximum transmission distance for given system impairment conveniently. The accuracy and the limitation of the database are also discussed.

ACKNOWLEDGMENTS

The work is supported in part by the National Natural Science Foundation of China (60478003) and the “Trans-Century Training Programme Foundation for the Talents by the Ministry of Education”.

REFERENCES

1. G. P. Agrawal, *Nonlinear Fiber Optics*, 3rd ed., Chap. 2, CA: Academic, San Diego, 2001.
2. J.-P. Elbers, A. Färbert, C. Scheerer, C. Glingener, and G. Fisher, “Reduced model to describe SPM-limited fiber transmission in dispersion-managed lightwave systems,” *IEEE J. Sel. Topics Quantum Electron.* 6, pp. 276-281, 2000.
3. S. Vorbeck and M. Schneiders, “Cumulative nonlinear phase shift as engineering rule for performance estimation in 160-Gb/s transmission systems,” *IEEE Photon. Technol. Lett.* 16, pp. 2571-2573, 2004.

4. J.-C. Antona, S. Bigo, and J.-P. Faure, "Nonlinear cumulated phase as a criterion to assess performance of terrestrial WDM systems," in *OFC*'2002, pp. 365-367, 2002.
5. B. Konrad and K. Petermann, "Optimum fiber dispersion in high-speed TDM systems," *IEEE Photon. Technol. Lett.* 13, pp. 299-301, 2001.
6. M. C. Jeruchim, P. Balaban, and K. S. Shanmugan, *Simulation of Communication Systems: Modeling, Methodology, and Techniques*, pp. 386-389, MA: Kluwer, Norwell, 2000.
7. A. Mecozzi, C. B. Clausen, M. Shtaif, S.-G. Park, and A. H. Gnauck, "Cancellation of timing and amplitude jitter in symmetric links using highly dispersed pulses," *IEEE Photon. Technol. Lett.* 13, pp. 445-447, 2001.
8. J. Kissing, S. Vorbeck, M. Plura, and E. Voges, "Design of high data rate optical transmission systems with self phase modulation and noise," *Electr. Eng.* 84, pp. 123-128, 2002.